

Features:

- complete package for automatic operation of the borehole pump and with additional dry-run protection
- oil-filled asynchronous motor within stainless steel housing with thermal contact
- jacket cooling for continuous duty horizontal / emerged
- sealed with high-grade mechanical seal
- brass bearing shield
- stainless steel pump housing and motor shaft
- modern, powerful pump hydraulics with impellers and guide wheels made of wear-resistant plastic

Application:

- water pumping from deep wells and rainwater cisterns
- domestic water supply, garden irrigation
- agriculture

Scope of delivery:

- pump with 20 m power cable and plug with integrated capacitor, power switch and motor protection
- electronic pressure switch with dry-run protection
- 10 m stainless steel rope with 4 rope clips
- non-return valve

Technical data:

Art.no.	U [V]	P ₁ [W]	P ₂ [W]	I _n [A]	n [min ⁻¹]	Q _{max} [m ³ /h]	H _{max} [m]	P0	D [mm]	L [mm]	W [mm]	H [mm]	Weight [kg]
11943	230	1.200	800	5,2	2800	4,5	68,0	G1	100	625	100	100	16,17

Characteristics:

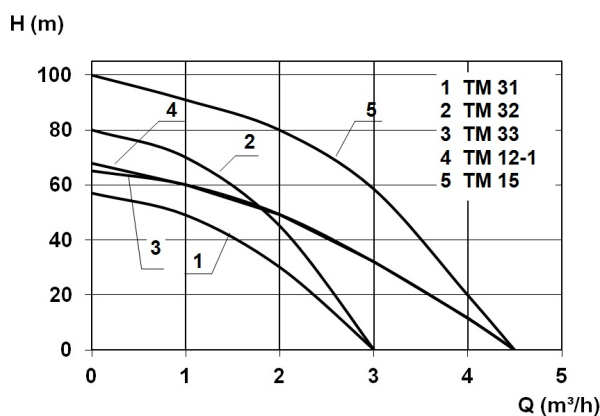

Product benefits:

- complete package for automatic operation
- dry-run protection for additional safety included in the scope of delivery
- jacket cooling for continuous duty horizontal / emerged

Materials:

Seal pump:	mechanical seal
Material pump housing:	stainless steel AISI 304

Example of installation:

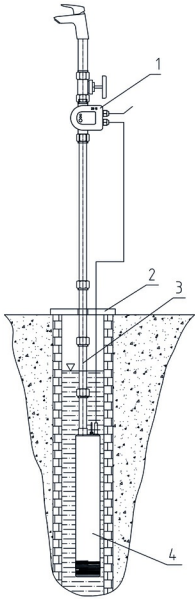

- | | |
|-----------------|--------------------|
| 1 Druckschalter | 3 Druckrohrleitung |
| 2 Brunnenkopf | 4 Pumpe |

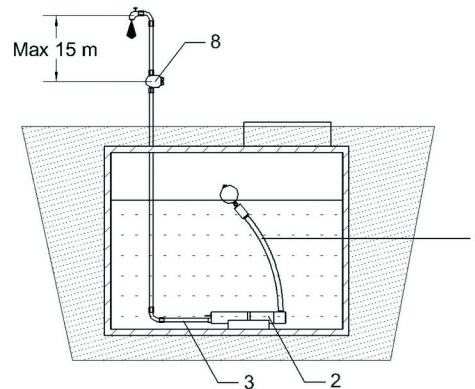

- | | |
|-------------------------|---------------------------------------|
| 1 schwimmende Entnahme | 3 Druckrohrleitung |
| 2 Pumpe mit Auflagerung | 8 Druckschalter mit Trockenlaufschutz |