

### Features:

- polyethylene container with 135 litres capacity and up to 75 litres switching volume
- simplex units with submersible waste water pump ZPK with float switch
- duplex units with 2 pumps ZPK and control unit with pneumatic level control ZPS2
- motor housing and shaft made of stainless steel, suction strainer, impeller and pump housing made of polypropylene
- piping made of PVC with external non-return valves and pressure outlet 1 1/4" FPT
- operation temperature 40°C (short-term 90°C)
- protection grade IP 57 - temporary submersible

### Application:

- as lifting unit for grease separators
- pumping of domestic waste water from washing machines, showers, washbasins etc.
- above-ground installation in frost-free rooms below the backflow level

### Scope of delivery:

- pre-assembled ready for connection with 3 m power cable and plug
- pressure outlet incl. non-return valve(s) and gate valve
- simplex unit incl. float switch
- duplex unit incl. ZPS2: comfortable, pneumatic level control with microcontroller, LCD plain text display for filling level, maintenance, operating hours, fault message and alarm signal in switchbox for indoor installation

### Technical data:

Art.no.	U [V]	P <sub>1</sub> [W]	P <sub>2</sub> [W]	In [A]	n [min <sup>-1</sup> ]	Q <sub>max</sub> [m <sup>3</sup> /h]	H <sub>max</sub> [m]	SH [mm]	PO	L [mm]	W [mm]	H [mm]	Weight [kg]
17458	230	850	430	3,7	2800	10,0	10,0	30	G 1 1/4	550	550	625	24

### Characteristics:

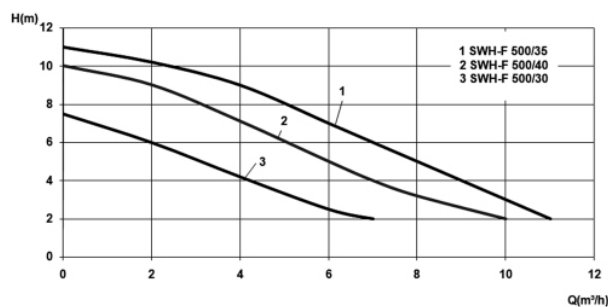

### Product benefits:

- grease-resistant container and pump made of polypropylene (no corrosion)
- double sealing by mechanical seal and additional shaft seal
- maintenance-friendly due to external non-return valve
- short-term up to 90°C medium temperature

### Materials:

Material impeller:	PA6 GV25
Seal motor:	shaft seal NBR
Seal pump:	mechanical seal carbon/ceramic/NBR
Material motor housing:	stainless steel AISI 316L
Material pump housing:	PP GF20
Material motor shaft:	stainless steel AISI 430F
Material container:	PE

**Dimensions:**

single unit

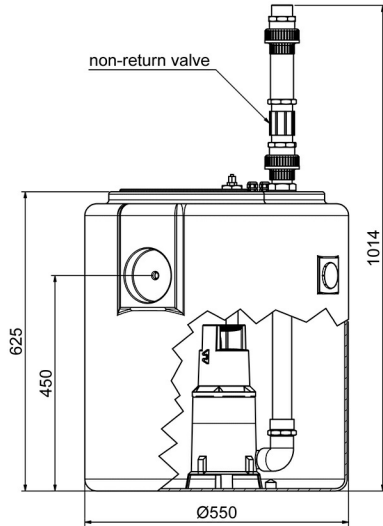

duplex unit

