

**Features:**

- packaged pumping station made of corrosion-resistant PE-LLD
- buoyancy-proof up to ground water level of max. 0,5 m from manhole's lower edge
- installation of one pump of the series ZFS 71, ZPG 50, ZPG 71
- stainless steel piping DN 32, pre-assembled with coupling system
- non-return valve, gate valve and flushing connection 1"
- pressure outlet PE-HD 63 x 5.8 – outside the manhole
- 1 x inlet DN 150, further inlets optional
- 2x connection DN 100 for cable gland and air vent

**Application:**

- pumping of sewage from single-family houses
- as drainage pumping station
- for pressure drainage
- for installation outside buildings
- also drivable with manhole covers class B and D

**Scope of delivery:**

- pumping station with pressure pipes and valves
- ZFS 71 series - grinder pump (except Art.no. 14483)
- BEGU manhole cover class A-D optional (see accessories)
- control unit ZPS for pumping station (ZPG 50 WA with float switch)

**Product benefits:**

- complete pumping station for domestic connections (1 pump)
- complete set - ready for connection available
- load capacity up to 40 tons (class D)
- divers pump options (e.g. ZFS 71, ZPG 50, ZPG 71)
- made of corrosion-resistant PE-LLD for lifelong operating time
- pre-assembled connections available
- quick-coupling system for easy pump insertion and optimal sealing

**Technical data:**

| Art.no. | U<br>[V] | P <sub>1</sub><br>[W] | P <sub>2</sub><br>[W] | In<br>[A] | n<br>[min <sup>-1</sup> ] | Q <sub>max</sub><br>[m <sup>3</sup> /h] | H <sub>max</sub><br>[m] | SH<br>[mm] | PO    | D<br>[mm] | L<br>[mm] | W<br>[mm] | H<br>[mm] | Weight<br>[kg] |
|---------|----------|-----------------------|-----------------------|-----------|---------------------------|---|-------------------------|------------|-------|-----------|-----------|-----------|-----------|----------------|
| 21574   | 230      | 1.250                 | 750                   | 6,0       | 2800                      | 23,0                                    | 11,9                    | 45         | DN 50 | 1100      | 1100      | 1100      | 1730      | 130            |

**Characteristics:**

**Materials:**

|                         |                             |
|-------------------------|-----------------------------|
| Material impeller:      | cast-iron GG25              |
| Seal motor:             | shaft seal SIC/SIC/NBR      |
| Seal pump:              | mechanical seal SIC/SIC/NBR |
| Material motor housing: | cast-iron GG25              |
| Material pump housing:  | cast-iron GG25              |
| Material motor shaft:   | stainless steel AISI 420    |
| Material container:     | PE                          |

**Dimensions:**

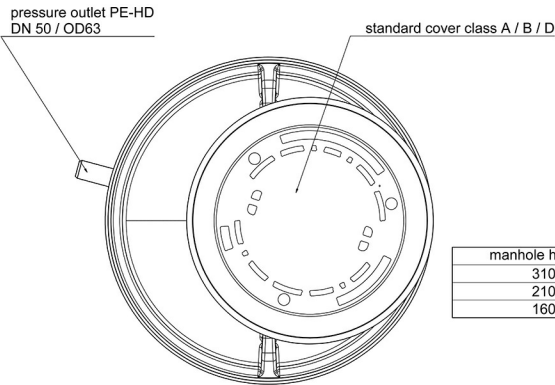
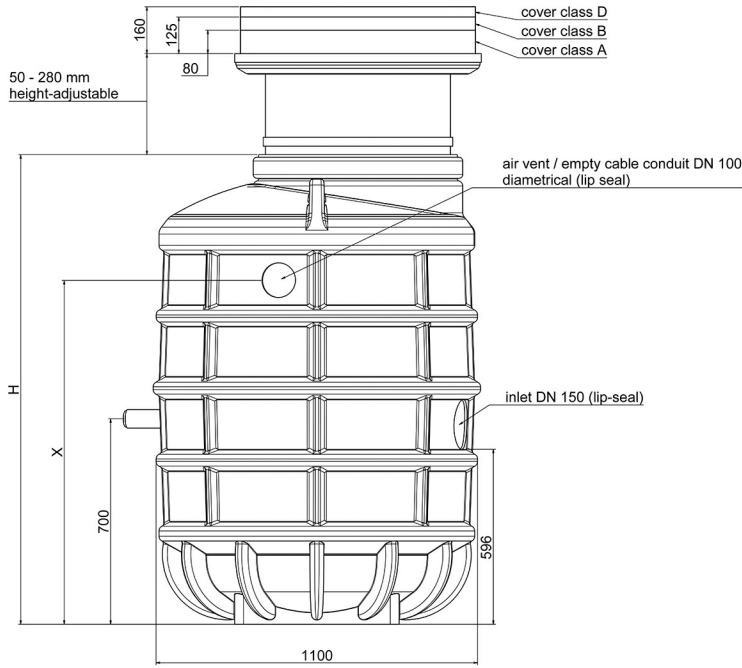

| manhole height: H | X    |
|-------------------|------|
| 3100              | 2675 |
| 2100              | 1675 |
| 1600              | 1175 |